

Description

The LM5D25N15 uses advanced trench technology to provide excellent $R_{DS(ON)}$, low gate charge and operation with gate voltages as low as 4.5V. This device is suitable for use as a Battery protection or in other Switching application.

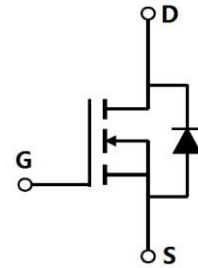

General Features

$V_{DS} = 150V$ $I_D = 25A$
 $R_{DS(ON)} < 52m\Omega$ @ $V_{GS} = 10V$

Application

- Battery protection
- Load switch
- Uninterruptible power supply

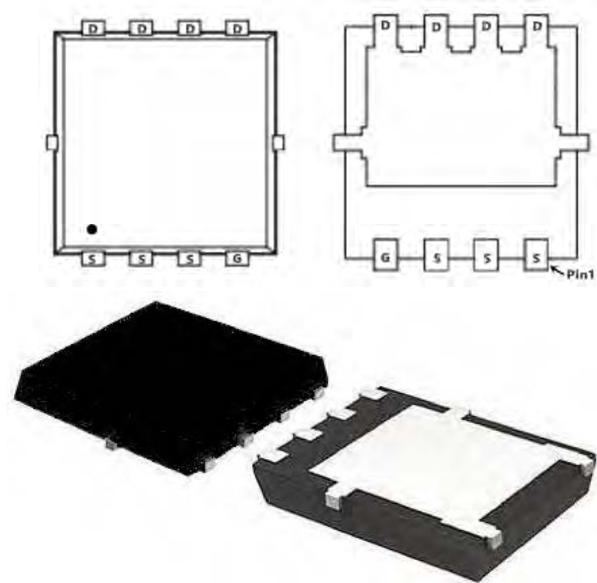

Package Marking and Ordering Information

| Device | Device Marking | Device Package | Reel Size | Tape width | Quantity |
|-----------|----------------|----------------|-----------|------------|------------|
| LM5D25N15 | AP25N15NF | DFN5X6-8 | - | - | 5000 units |

Absolute Maximum Ratings ($T_c = 25^\circ C$ unless otherwise noted)

| Symbol | Parameter | Rating | Units |
|---------------------------|--|------------|--------------|
| V_{DS} | Drain-Source Voltage | 150 | V |
| V_{GS} | Gate-Source Voltage | ± 20 | V |
| $I_D @ T_c = 25^\circ C$ | Continuous Drain Current ¹ | 25 | A |
| $I_D @ T_c = 100^\circ C$ | Continuous Drain Current ¹ | 16 | A |
| $I_D @ T_A = 25^\circ C$ | Continuous Drain Current ¹ | 4.5 | A |
| $I_D @ T_A = 70^\circ C$ | Continuous Drain Current ¹ | 3.8 | A |
| IDM | Pulsed Drain Current ² | 60 | A |
| $P_D @ T_c = 25^\circ C$ | Total Power Dissipation ³ | 72.6 | W |
| $P_D @ T_A = 25^\circ C$ | Total Power Dissipation ³ | 2.7 | W |
| TSTG | Storage Temperature Range | -55 to 175 | $^\circ C$ |
| T_J | Operating Junction Temperature Range | -55 to 175 | $^\circ C$ |
| $R_{\theta JA}$ | Thermal Resistance Junction-ambient ¹ | 55 | $^\circ C/W$ |
| $R_{\theta JC}$ | Thermal Resistance Junction-Case ¹ | 2.0 | $^\circ C/W$ |

Electrical Characteristics (T_J=25°C, unless otherwise noted)

| Symbol | Parameter | Conditions | Min. | Typ. | Max. | Unit |
|---------------------|--|---|------|------|------|------|
| BV _{DSS} | Drain-Source Breakdown Voltage | V _{GS} =0V, I _D =250μA | 150 | 165 | --- | V |
| R _{DS(ON)} | Static Drain-Source On-Resistance ² | V _{GS} =10V, I _D =20A | --- | 43 | 52 | mΩ |
| R _{DS(ON)} | Static Drain-Source On-Resistance ² | V _{GS} =10V, I _D =10A | --- | 45 | 70 | mΩ |
| V _{GS(th)} | Gate Threshold Voltage | V _{GS} =V _{DS} , I _D =250μA | 1.2 | 1.8 | 2.5 | V |
| I _{DSS} | Drain-Source Leakage Current | V _{DS} =120V, V _{GS} =0V, T _J =25°C | --- | --- | 1 | μA |
| | | V _{DS} =120V, V _{GS} =0V, T _J =55°C | --- | --- | 5 | |
| I _{GSS} | Gate-Source Leakage Current | V _{GS} =±20V, V _{DS} =0V | --- | --- | ±100 | nA |
| g _{fs} | Forward Transconductance | V _{DS} =5V, I _D =10A | --- | 25 | --- | S |
| Q _g | Total Gate Charge | V _{DS} =75V, V _{GS} =10V, I _D =10A | --- | 23 | --- | nC |
| Q _{gs} | Gate-Source Charge | | --- | 5.8 | --- | |
| Q _{gd} | Gate-Drain Charge | | --- | 4.2 | --- | |
| T _{d(on)} | Turn-On Delay Time | V _{DD} =75V, V _{GS} =10V, R _G =3.3Ω, I _D =10A | --- | 16.2 | --- | ns |
| T _r | Rise Time | | --- | 18.6 | --- | |
| T _{d(off)} | Turn-Off Delay Time | | --- | 28.5 | --- | |
| T _f | Fall Time | | --- | 6.5 | --- | |
| C _{iss} | Input Capacitance | V _{DS} =75V, V _{GS} =0V, f=1MHz | --- | 1190 | --- | pF |
| C _{oss} | Output Capacitance | | --- | 73 | --- | |
| C _{rss} | Reverse Transfer Capacitance | | --- | 4 | --- | |
| I _s | Continuous Source Current ^{1,4} | V _G =V _D =0V, Force Current | --- | --- | 20 | A |
| V _{SD} | Diode Forward Voltage ² | V _{GS} =0V, I _s =1A, T _J =25°C | --- | --- | 1.2 | V |
| t _{rr} | Reverse Recovery Time | I _F =10A, dI/dt=100A/μs, T _J =25°C | --- | 45 | --- | nS |
| Q _{rr} | Reverse Recovery Charge | T _J =25°C | --- | 138 | --- | nC |

Note :

- 1、 The data tested by surface mounted on a 1 inch 2 FR-4 board with 2OZ copper.
- 2、 The data tested by pulsed , pulse width ≅ 300us , duty cycle ≅ 2%
- 3、 The power dissipation is limited by 150°C junction temperature
- 4、 The data is theoretically the same as I_D and I_{DM} , in real applications , should be limited by total power dissipation.

Typical Electrical and Thermal Characteristics

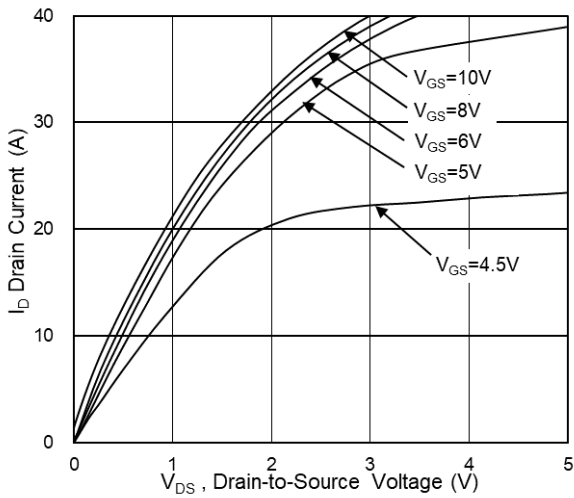

Fig.1 Typical Output Characteristics

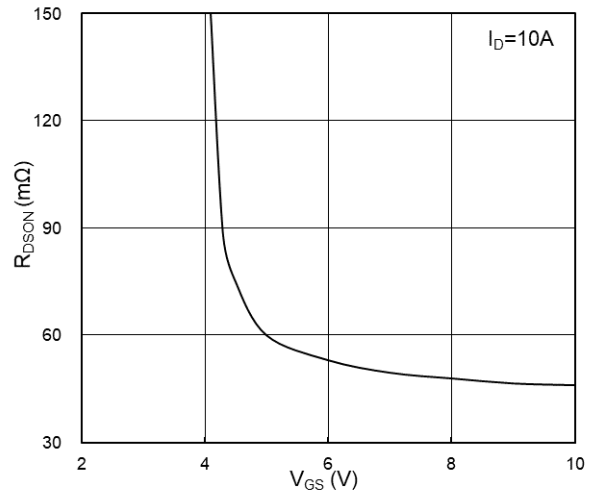

Fig.2 On-Resistance vs G-S Voltage

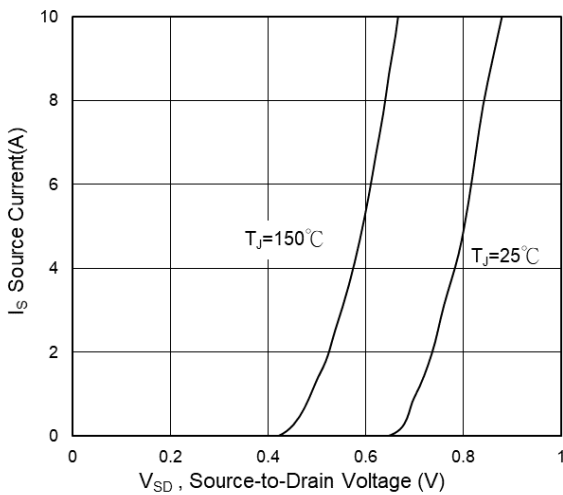

Fig.3 Source Drain Forward Characteristics

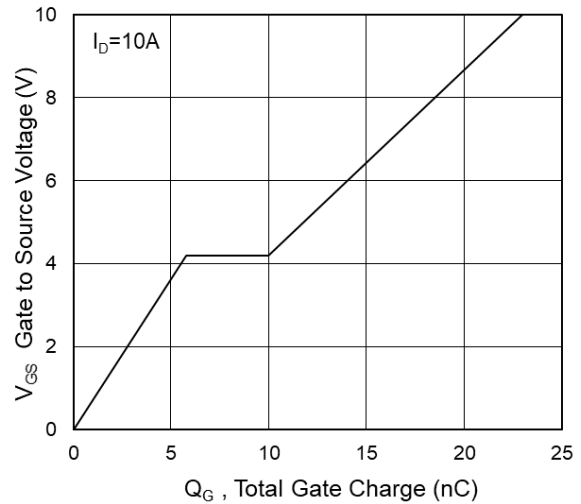

Fig.4 Gate-Charge Characteristics

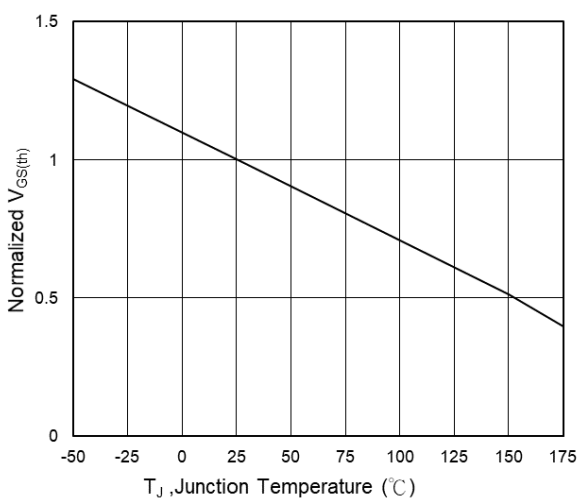

Fig.5 Normalized $V_{GS(th)}$ vs T_J

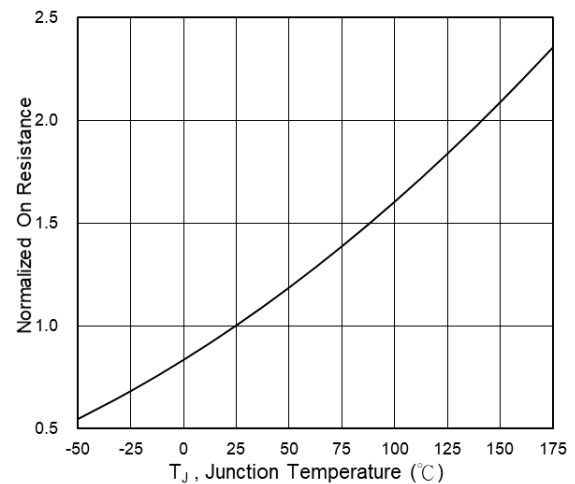

Fig.6 Normalized $R_{DS(on)}$ vs T_J

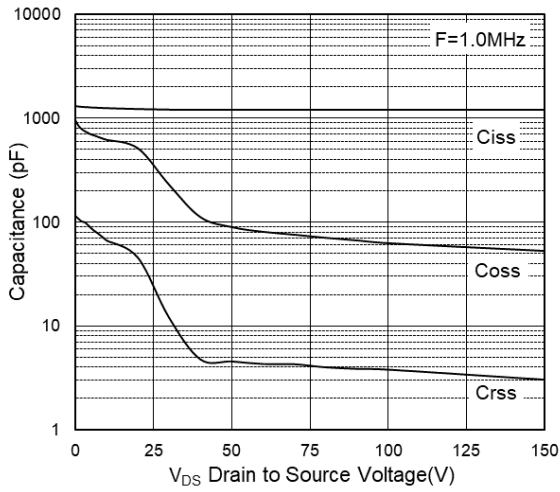

Fig.7 Capacitance

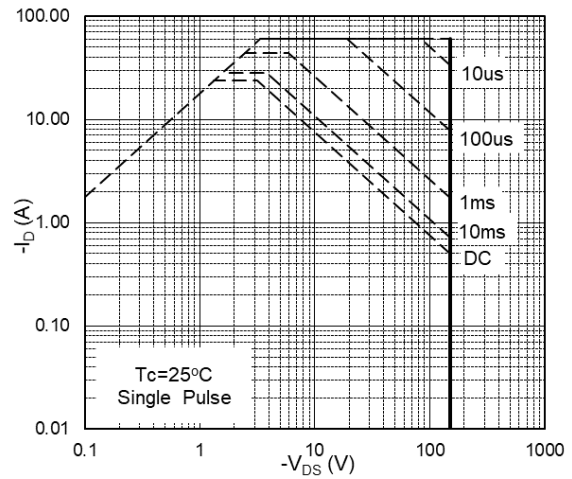

Fig.8 Safe Operating Area

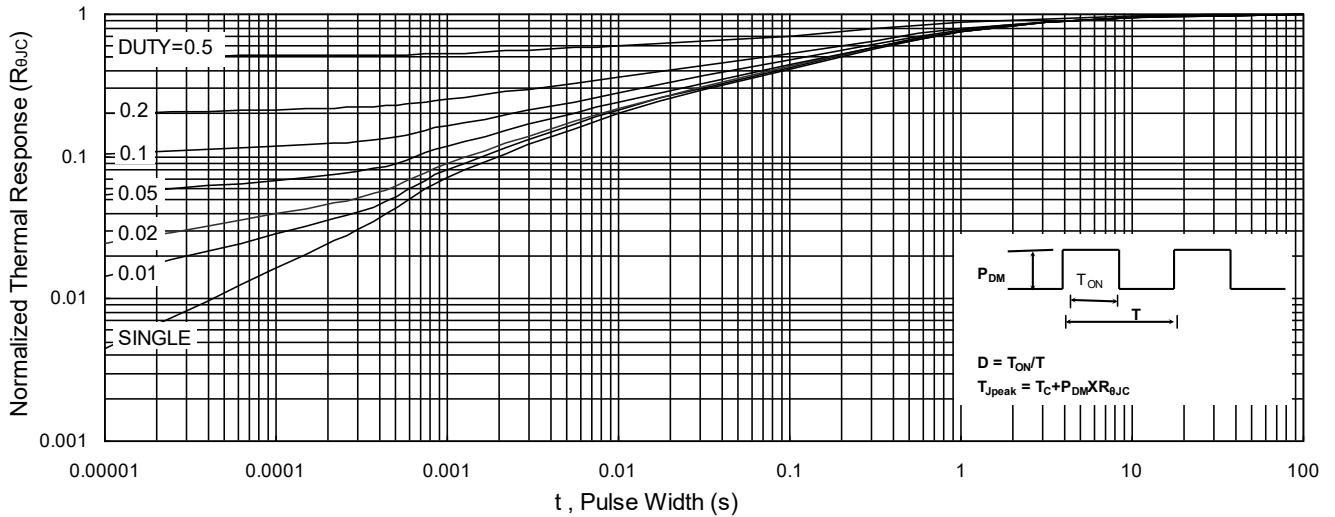

Fig.9 Normalized Maximum Transient Thermal Impedance

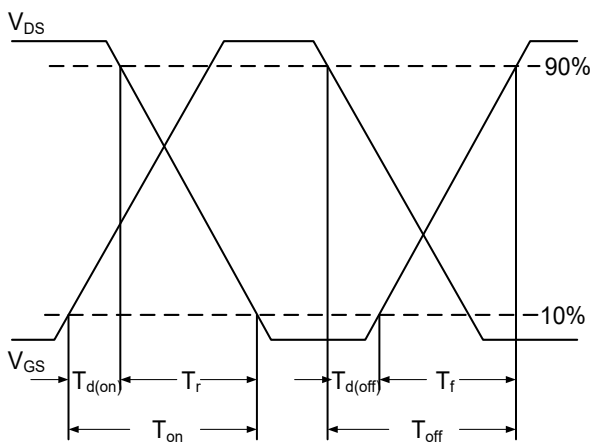

Fig.10 Switching Time Waveform

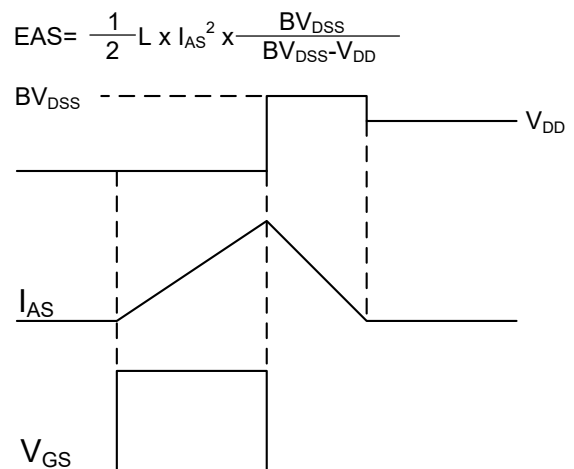
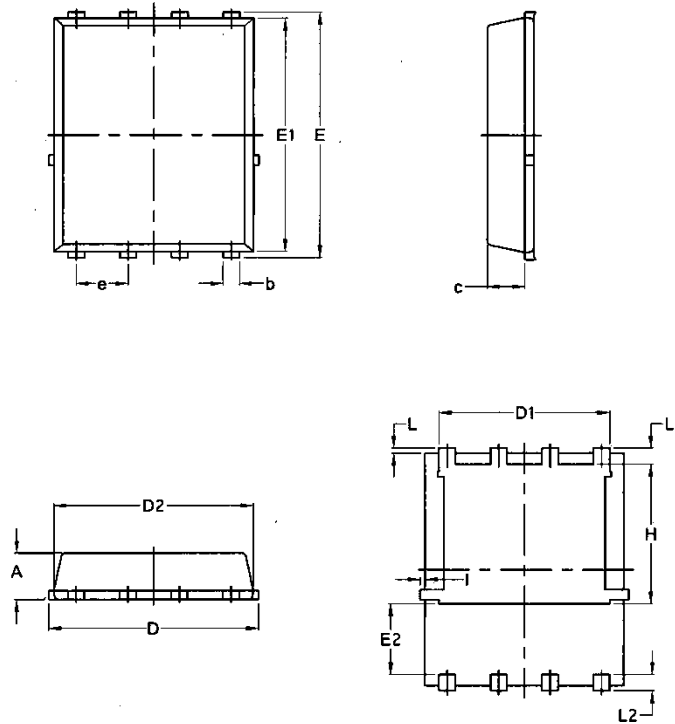

Fig.11 Unclamped Inductive Switching Waveform

Package Mechanical Data-DFN5*6-8 -JQ Single



| Symbol | Common | | | |
|--------|----------|--------|----------|--------|
| | mm | | Inch | |
| | Mim | Max | Min | Max |
| A | 1.03 | 1.17 | 0.0406 | 0.0461 |
| b | 0.34 | 0.48 | 0.0134 | 0.0189 |
| c | 0.824 | 0.0970 | 0.0324 | 0.082 |
| D | 4.80 | 5.40 | 0.1890 | 0.2126 |
| D1 | 4.11 | 4.31 | 0.1618 | 0.1697 |
| D2 | 4.80 | 5.00 | 0.1890 | 0.1969 |
| E | 5.95 | 6.15 | 0.2343 | 0.2421 |
| E1 | 5.65 | 5.85 | 0.2224 | 0.2303 |
| E2 | 1.60 | / | 0.0630 | / |
| e | 1.27 BSC | | 0.05 BSC | |
| L | 0.05 | 0.25 | 0.0020 | 0.0098 |
| L1 | 0.38 | 0.50 | 0.0150 | 0.0197 |
| L2 | 0.38 | 0.50 | 0.0150 | 0.0197 |
| H | 3.30 | 3.50 | 0.1299 | 0.1378 |
| I | / | 0.18 | / | 0.0070 |

Shanghai Leiditech Electronic Co.,Ltd
 Email: sale1@leiditech.com
 Tel : +86- 021 50828806
 Fax : +86- 021 50477059