

Features

- Ultra low leakage: nA level
- Operating voltage: 5V
- Low clamping voltage
- Complies with following standards:
 - IEC 61000-4-2 (ESD) immunity test
 - Air discharge: $\pm 20\text{kV}$
 - Contact discharge: $\pm 20\text{kV}$
 - IEC61000-4-4 (EFT) 40A (5/50ns)
 - IEC61000-4-5 (Lightning) 5A/10A (8/20 μs)
- RoHS Compliant

Applications

- USB Ports
- SIM Ports
- Smart Phones
- Wireless Systems
- Set-top box and digital TV
- Digital video interface (DVI)
- Ethernet 10/100/1000 Base T

Mechanical Characteristics

- Package: SOT-143
- Lead Finish: Matte Tin
- Case Material: "Green" Molding Compound.
- Moisture Sensitivity: Level 3 per J-STD-020
- Quantity Per Reel: 3000pcs
- Reel Size: 7 inch
- Device Marking: U5V0

Absolute Maximum Ratings (T_{amb}=25°C unless otherwise specified)

Parameter	Symbol	Value	Unit
Peak Pulse Power (8/20 μs)	P _{pp}	150	W
ESD per IEC 61000-4-2 (Air)	V _{ESD}	± 20	kV
ESD per IEC 61000-4-2 (Contact)		± 20	
Operating Temperature Range	T _J	-55 to +125	°C
Storage Temperature Range	T _{STJ}	-55 to +150	°C

Dimensions SOT-143

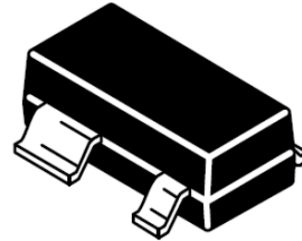

Pin Configuration

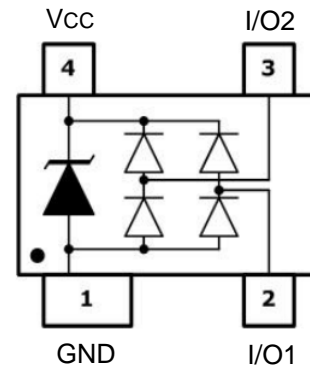

Electrical Characteristics(TA=25°C unless otherwise specified)

Parameter	Symbol	Test Condition	Min	Typ	Max	Unit
Reverse Working Voltage	V_{RWM}				5	V
Breakdown Voltage	V_{BR}	$I_T = 1mA$	6			V
Reverse Leakage Current	I_R	$V_{RWM} = 5V$			0.1	μA
Clamping Voltage	V_C	$I_{PP} = 1A$ (8 x 20 μs pulse) I/O to GND & VCC to GND			10	V
Clamping Voltage	V_C	$I_{PP} = 5A$ (8 x 20 μs pulse) I/O to GND			15	V
Clamping Voltage	V_C	$I_{PP} = 10A$ (8 x 20 μs pulse) VCC to GND			15	V
Junction Capacitance	C_J	$V_R = 0V$, $f = 1MHz$ I/O to GND		0.45	0.6	pF
Junction Capacitance	C_J	$V_R = 0V$, $f = 1MHz$ I/O to I/O		0.22	0.3	pF

Typical Performance Characteristics(TA=25°C unless otherwise specified)

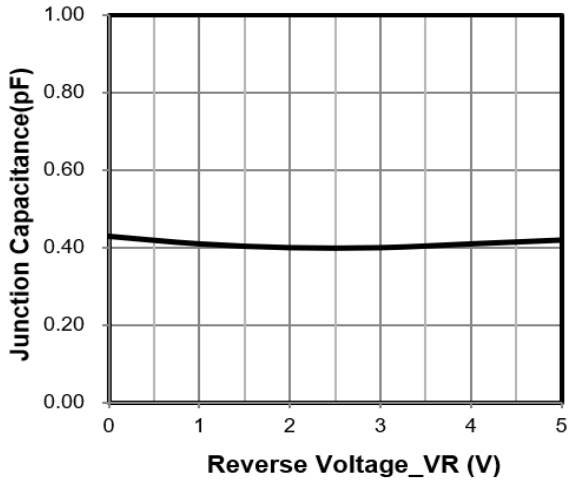

Junction Capacitance vs. Reverse Voltage

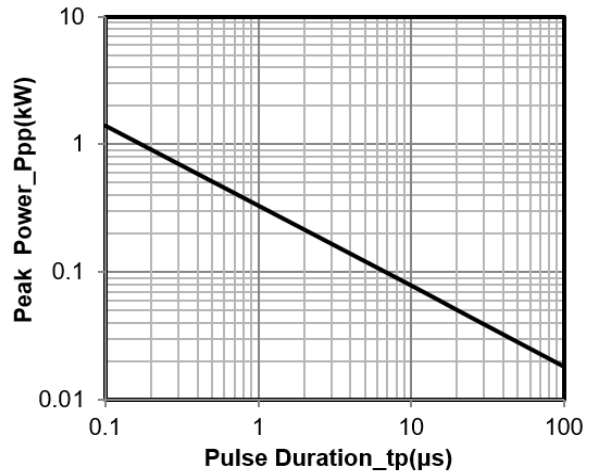

Peak Pulse Power vs. Pulse Time

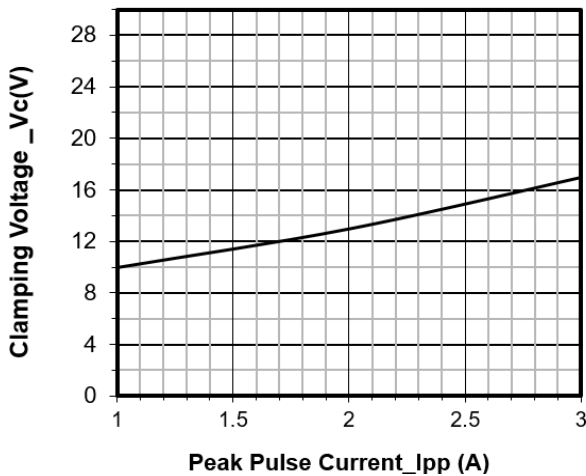

Clamping Voltage vs. Peak Pulse Current

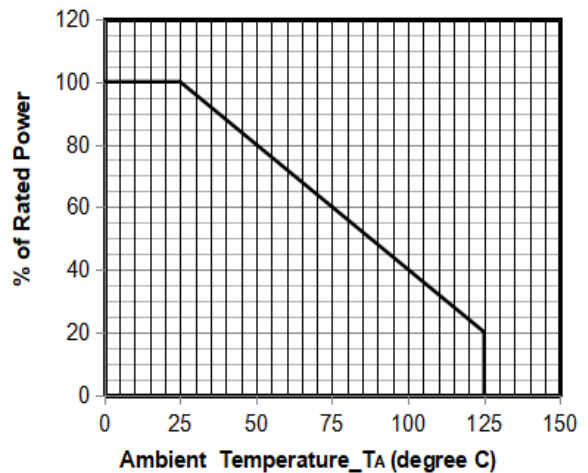

Power Derating Curve

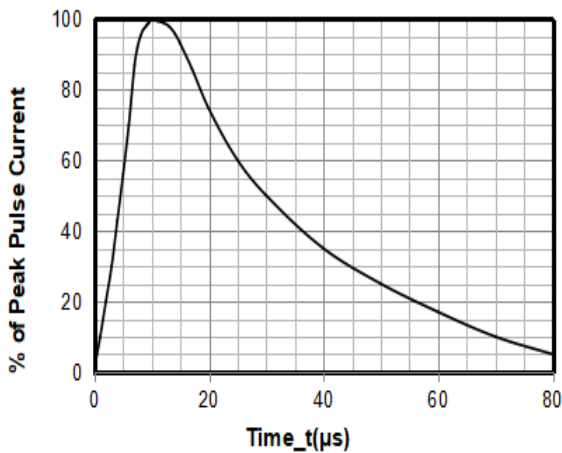

8 X 20μs Pulse Waveform

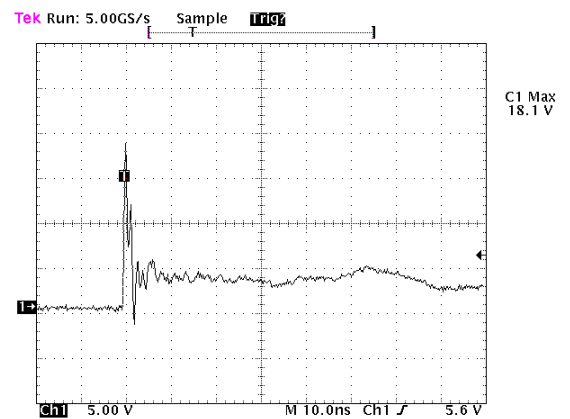

Note: Data is taken with a 10x attenuator

ESD Clamping Voltage

8 kV Contact per IEC61000-4-2

SOT-143 Package Outline Drawing

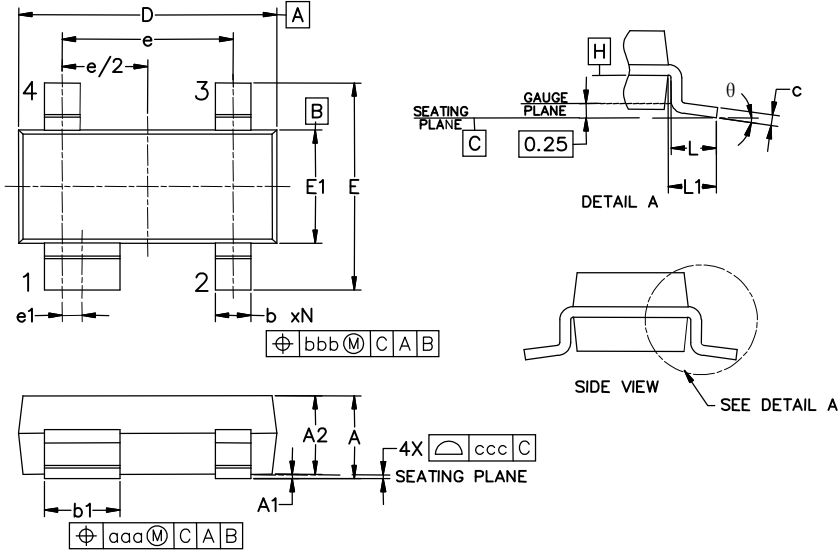

Symbol	Inches			Millimeters		
	Min.	Nom.	Max.	Min.	Nom.	Max.
A	0.031	-	0.048	0.80	-	1.22
A1	0.000	-	0.008	0.013	-	0.15
A2	0.020	0.035	0.042	0.75	0.90	1.07
b	0.011	-	0.020	0.30	-	0.51
b1	0.029	-	0.037	0.76	-	0.94
c	0.003	-	0.008	0.08	-	0.20
D	0.110	0.114	0.120	2.80	2.90	3.04
E	0.082	0.093	0.104	2.10	2.37	2.64
E1	0.047	0.051	0.055	1.20	1.30	1.40
e	0.075			1.92 BSC		
e1	0.008			0.20 BSC		
L	0.015	0.020	0.024	0.40	0.50	0.60
L1	(0.021)			(0.54)		
N	4			4		
θ	0°	-	8°	0°	-	8°
aaa	0.006			0.15		
bbb	0.008			0.20		
ccc	0.004			0.10		

Suggested Land Pattern

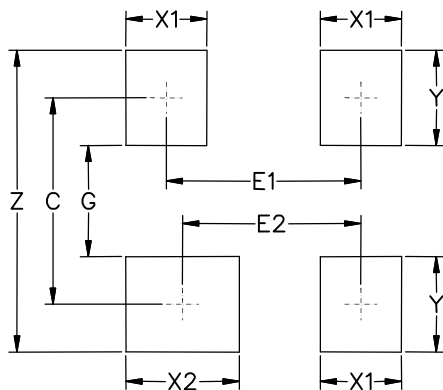

Symbol	Inches	Millimeters
C	(0.087)	(2.20)
E1	0.076	1.92
E2	0.068	1.72
G	0.031	0.80
X1	0.039	1.00
X2	0.047	1.20
Y	0.055	1.40
Z	0.141	3.60

NOTICE

Leiditech reserves the right to make modifications, enhancements, improvements, corrections or other changes without further notice to any product herein. Leiditech does not assume any liability arising out of the application or use of any product described herein.